

PNEUMATIC MOUNTS SLM



(1) Natural frequency:
3 to 5 Hz

DESCRIPTION

SLM pneumatic mounts are made from synthetic rubber and are laterally reinforced with steel springs.

The base plate is bored with 4 smooth holes to allow a possible fixing on the ground and the valve allows to inflate the mount in the same way as an automobile tyre.

- Elastomer body (temperature range -30°C à $+180^{\circ}\text{C}$) resistant to oils, the majority of solvents and natural ageing.
- The top and bottom plates are available in both steel and aluminium.

OPERATION

The design of SLM mounts gives the following basics characteristics:

- In the event of loss of pressure, the machine will rest on the elastomer body. The load capacity of the mounting remains unchanged.
- The ratio of horizontal rigidity and vertical rigidity of the SLM is 1:1, which allows excellent stability.

Advantages:

- Eight sizes, capacity range of 10 daN to 10000 daN.
- Allow you to level the machine gradually while varying the air pressure.
- Possibility of varying the natural frequency, by varying the air pressure.

APPLICATIONS

- Industrial plant, compressors, conveyors, vacuum pumps, generators, air-conditioners, diesel engines, ventilators, presses with fast cycle, machine tools.
- Metrology: measuring apparatus sensitive to the external disturbances, optical instruments, etc.

(1) Natural frequencies with max/min loads, see : OPERATING CHARACTERISTICS.

DIMENSIONS AND OPERATING CHARACTERISTICS

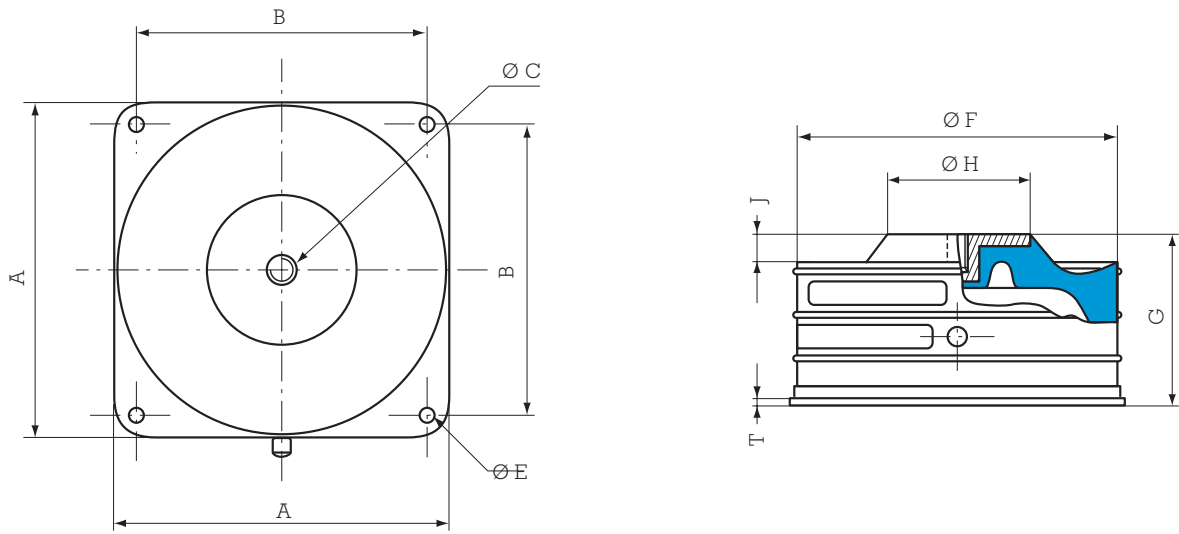

Paulstra reference	Barry Controls * reference	Nominal static load daN	A mm	B mm	Ø C	Ø E mm	Ø F mm	G mm	Ø H mm	J mm	T mm	Weig. kg
530904 01	SLM-M1A	11 - 45	76.2	60.4	M10	12	73.2	63.5	25.4	12.7	3.2	0.5
530904 02	SLM-M3A	34 - 136	106.4	88.9	M12	14	105.2	62.2	44.4	12.7	3.2	0.7
530904 03	SLM-M6A	68 - 272	130.0	108.0	M12	14	126.7	88.9	54.1	14.2	3.2	1.5
530904 04	SLM-M12A	136 - 545	174.8	152.4	M12	14	171.2	88.9	76.2	14.2	3.2	2.5
530904 05	SLM-M24A	272 - 1090	254.0	215.9	M16	19	245.4	88.9	138.2	14.2	4.8	6
530904 06	SLM-M48A	545 - 2180	342.9	304.8	M16	19	338.1	88.9	190.5	14.2	4.8	11.8
530904 07	SLM-M96A	1090 - 4360	469.9	406.4	M24	22	468.4	88.9	266.7	14.2	6.4	26.0
530904 08	SLM-M192A	2180 - 8720	609.6	508.0	M24	22	609.6	88.9	400.1	14.2	6.4	45.0

See current price list for availability of items.

1 kg ≈ 1 daN

* Barry Controls references are given as an indication.

PRESSURE OF INFLATION FOR STATIC HEAD AND NATURAL FREQUENCY

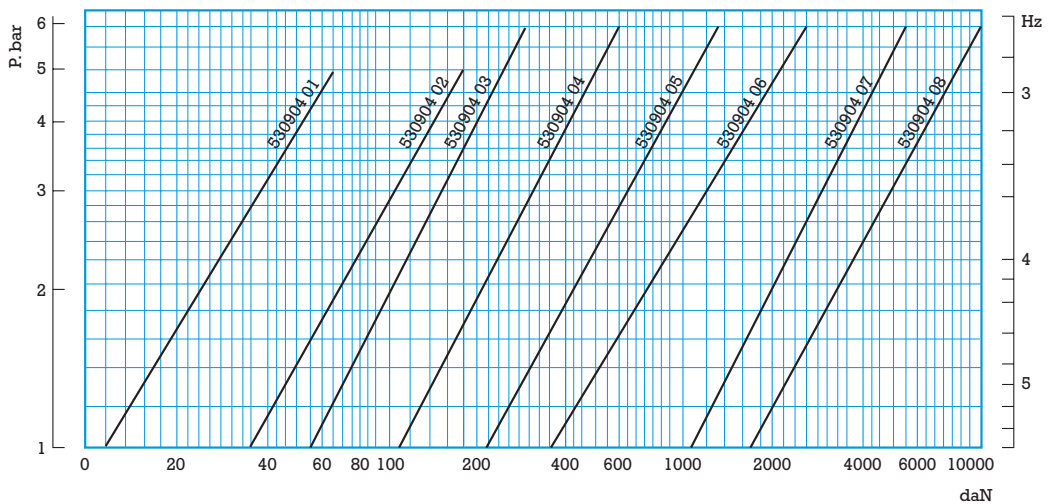

ASSEMBLY

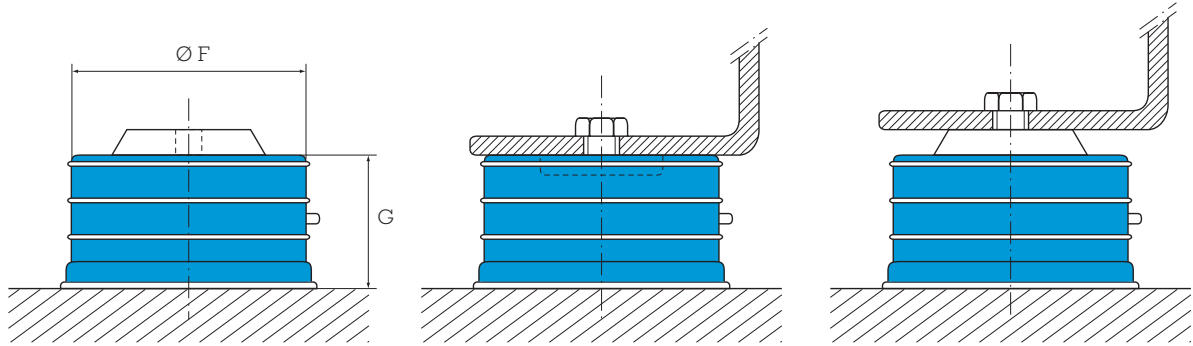

1 - AV mount

2 - Install the machinery

3 - Inflate the mount

Correct assembly

Recommendations:

- The machine must rest on the supports before they are inflated to the level indicated on dimension " G ".
- Before any disassembling, the SLM mount must be deflated.
- The surface of the machine must completely cover the surface ($\varnothing F$) of the mount. If it is not possible, use a separate plate (thickness between 5 and 10 mm, according to the load) and diameter equal to $F + 10$ mm. This is to obtain a base on the full surface. It is required for assembly and in the event of an air leakage.
- If necessary, it is possible to fix the supports using the four smooth holes on the bed plate.
- Make sure care that the valves are protected.
- Never overload the mounts. Always use the recommended load capabilities.

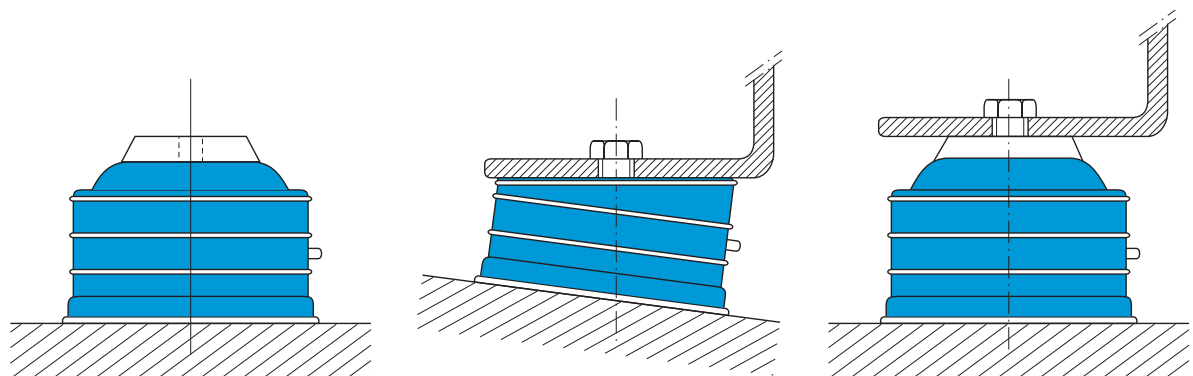

Mount inflated before fixing the machinery

Floor not level

Over inflated mount

Uncorrect assemblies